

# NIKKEN ROTARY TABLES



HIGH  
ACCURACY



INCREASED  
PRODUCTION



TROUBLE-FREE  
LONG LIFE

[www.lyndexnikken.com](http://www.lyndexnikken.com)

**NIKKEN**

**LN**   
LYNDEX-NIKKEN

# TABLE OF CONTENTS

<b>NIKKEN ROTARY TABLE LINEUP .....</b>	<b>Pages 4-5</b>
<b>NIKKEN ROTARY TABLE FEATURES.....</b>	<b>Page 6</b>
<b>HORIZONTAL APPLICATION.....</b>	<b>Page 7</b>
<b>OKUMA ROTARY TABLE MATRIX .....</b>	<b>Pages 8-9</b>
<b>ROTARY TABLE SPECIFICATIONS</b>	
<b>CNC180, 202, 260 .....</b>	<b>Pages 10-11</b>
<b>CNC302, 321, 401.....</b>	<b>Pages 12-13</b>
<b>NCT200, 200E .....</b>	<b>Pages 14-15</b>
<b>5AX-130, 201 .....</b>	<b>Pages 16-17</b>
<b>5AX-250, 350 .....</b>	<b>Pages 18-19</b>
<b>CNC260T, 321T .....</b>	<b>Pages 20-21</b>
<b>CNC401T, 601T .....</b>	<b>Pages 22-23</b>
<b>M460-VE ROTARY TABLE LAYOUT (4TH/5TH AXIS) .....</b>	<b>Page 24</b>
<b>M560-V ROTARY TABLE LAYOUT (4TH/5TH AXIS).....</b>	<b>Page 25</b>
<b>ROTARY TABLE ACCESSORIES.....</b>	<b>Page 26</b>
<b>WORKHOLDING.....</b>	<b>Page 27</b>
<b>SERVICE AND REPAIR .....</b>	<b>Page 28</b>
<b>ROTARY TABLE CHECK-UP PROGRAM .....</b>	<b>Page 29</b>
<b>ROTARY TABLE VIDEOS.....</b>	<b>Page 30</b>

## OKUMA PARTNER IN TECHNOLOGY

Lyndex-Nikken products seamlessly integrate with Okuma machining centers, allowing you to reduce cycle times and achieve maximum efficiency. As a member of Partners in Technology, we are working hand-in-hand with Okuma engineers and continuing to find new ways to maximize your manufacturing capability.

You can see Lyndex-Nikken rotary tables, live tools, and toolholders on demonstration on Okuma machining centers at the Partners in Technology facility in Charlotte, NC.



**OKUMA PARTNERS**  
IN TECHNOLOGY

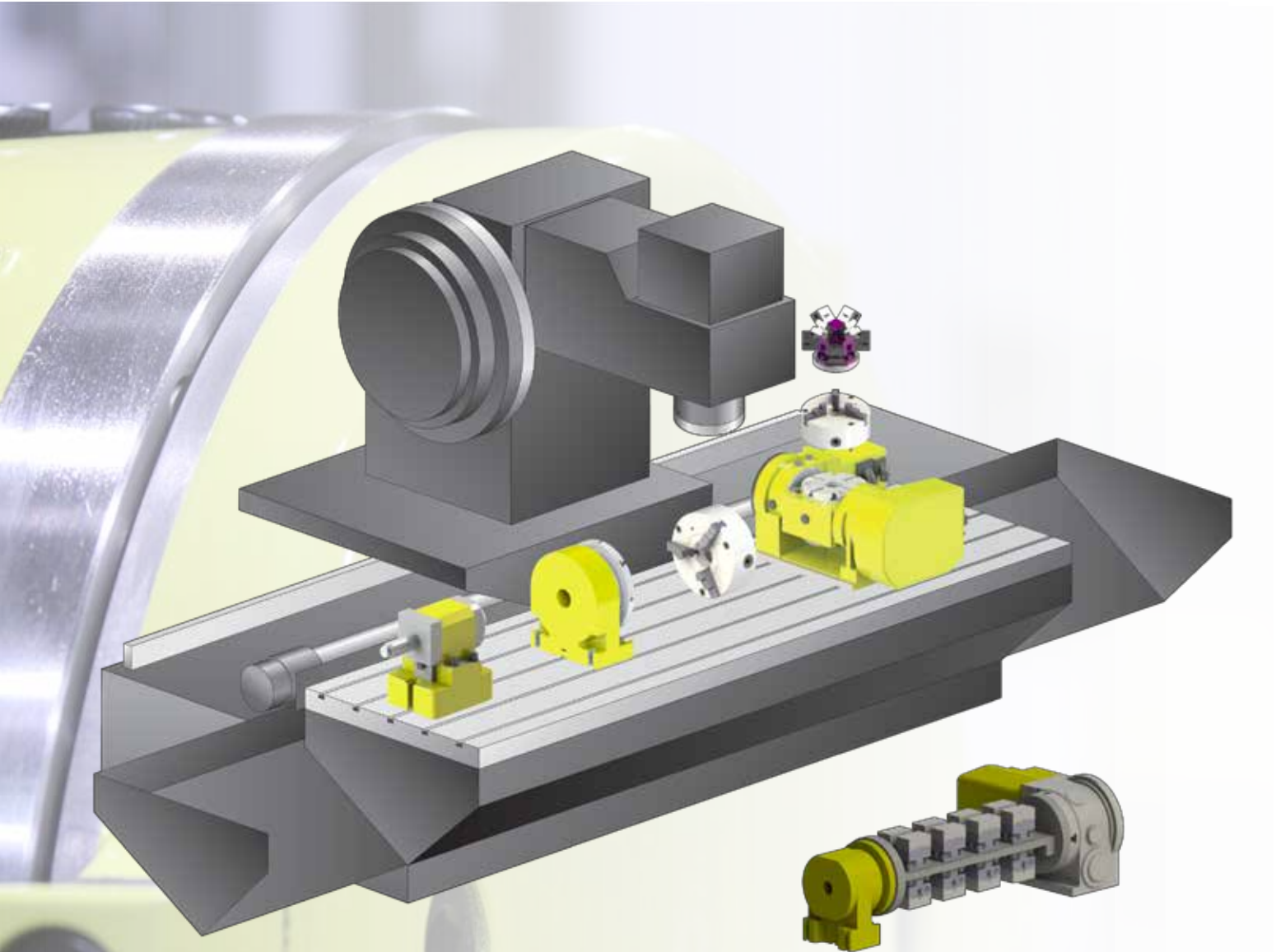

## WORKHOLDING

Our range of modular workholding integrates seamlessly with our multi axis platform approach. Zero point location and modular base rail technology are available to suit NIKKEN standard table interfaces. This allows rapid change over of component fixtures and workholding set ups.

Standard clamping modules, centring vices and chucks are all interchangeable with machine bed and additional axes, in addition a wide range of standard and bespoke trunnion set ups are available as options.



# NIKKEN ROTARY TABLE LINEUP

## CNC ROTARY TABLES



### COMPACT

CNC105, 180, 202

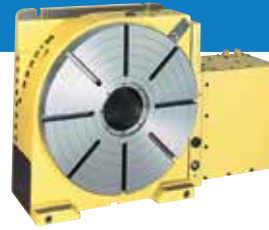

### STANDARD

CNC260, 302, 321, 401,  
501, 601, 803, 1003

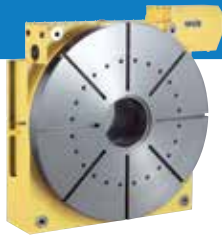

### LARGE

CNC1000, 1200,  
1201, 1600



### TOP SIDE MOTOR MOUNTED

CNC202T, 260T, 302T,  
321T, 401T, 501T, 601T

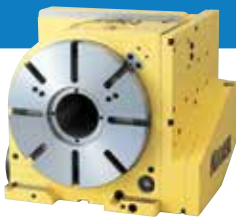

### BACK SIDE MOTOR MOUNTED

CNC180B, 202B, 260B,  
302B, 321B, 401B

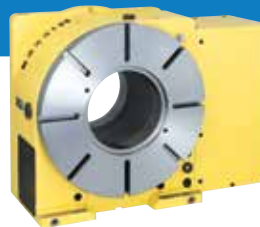

### BIG BORE

CNCB350, B450, B630



### MULTI-SPINDLE

CNC100-2W, 3W, 4W,  
180-2W, 202-2W, 260-2W

## NSV ULTRA PRECISION ROTARY HIRTH COUPLING INDEX

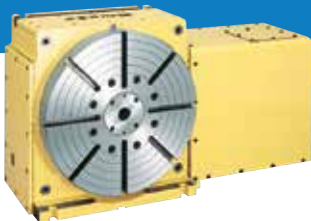

### HIRTH COUPLING INDEX

NSVZ180, 300  
NSVX400, 400T, 500

## NCT ROTARY TABLES



### COMPACT

**NEW** NCT200, NCT200E

## 5AX TILTING ROTARY TABLES



### COMPACT

**NEW 5AX-100, 130, 201**



### STANDARD

**5AX-230, 250, 350, 550**

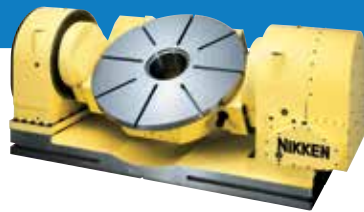

### LARGE

**5AX-800, 1200**



### MULTI-SPINDLE

**5AX-2MT-105, 4MT-105**

NIKKEN NC TABLES offer unrivaled quality and performance by optimizing production and can be configured for all types of machining centers.

NIKKEN offers a wide range of 4th and 5th axis tables that can be easily configured to a variety of workholding solutions such as trunnion fixtures, built-in rotary joints for facilitating hydraulic clamping, chucking and vice systems. The range consists of gear driven and direct drive units which can be controlled by the machine tool directly or via our own Alpha21 control system.



# NIKKEN ROTARY TABLE FEATURES

**1. Worm Wheel** - The fine pitch of the NIKKEN worm wheel contributes to 4 arc second repeatability. NIKKEN's unique construction shrink fits the worm wheel onto the solid faceplate and quill body.

The NIKKEN worm wheel and screw system in conjunction with the tables higher speed rates create a hydro-static high pressure oil film, virtually eliminating the wear between the gears.

**2. Worm Screw** - The NIKKEN worm screw is a combination of special hardened steel and custom made carbide. As a consequence, and ultimately a benefit, friction between the screw and worm wheel is eliminated. The thread ground carbide worm gear and honed steel worm wheel are hand matched and paired to maintain maximum thread engagement and rotation accuracy (this also adds to the rigidity overall).

**3. Casting** - NIKKEN Rotary Tables utilize fine grain high-density Grey Cast Iron. These castings offer long-term stability, low distortion with high strength and rigidity. The castings are rough machined, after which a period of 30 days is allowed for the casting to stabilize before the rotary table is prepared for and put through the finish machining process.

**4. Faceplate** - Our design features a much shorter distance from the faceplate to the gear. This means that greater torsional forces can be sustained. Braking is applied directly to the spindle which is of a mono block construction incorporating the faceplate, adding greater rigidity overall.

**5. Radial Bearing System** - Located directly under the edge of faceplate is the Radial Bearing System. This position maximizes load distribution. We also incorporate a Teflon seal in lieu of an 'O' Ring. The bearings are hand picked and matched (in increments of 1 micron) between rotary table and faceplate assembly, insuring the utmost rotation accuracy and elimination of unnecessary movement between the two parts.



## LYNDEX-NIKKEN

Nikken's unique design shrink fits the worm wheel onto the solid faceplate and quill body. This along with the hand pairing of the carbide worm screw eliminates backlash.

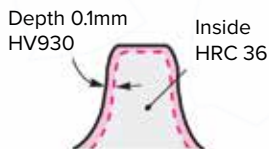

A much shorter distance from face plate to gear allows for greater torsional forces to be sustained.

The fine pitch of the worm wheel contributes to 4 arc second repeatability.

The material used for the Nikken worm wheel is custom made steel, specially hardened and ion nitrided on the teeth. As a consequence, frictions between the gears are eliminated.



**Lyndex-Nikken is pleased to offer Top Mount rotary tables with optional swing box and cable management.**

## TOOLING PACKAGES ARE AVAILABLE

Call us for options to get the most out of your Okuma CNC Machining Center. Standard and Advanced Tooling Packages are available.

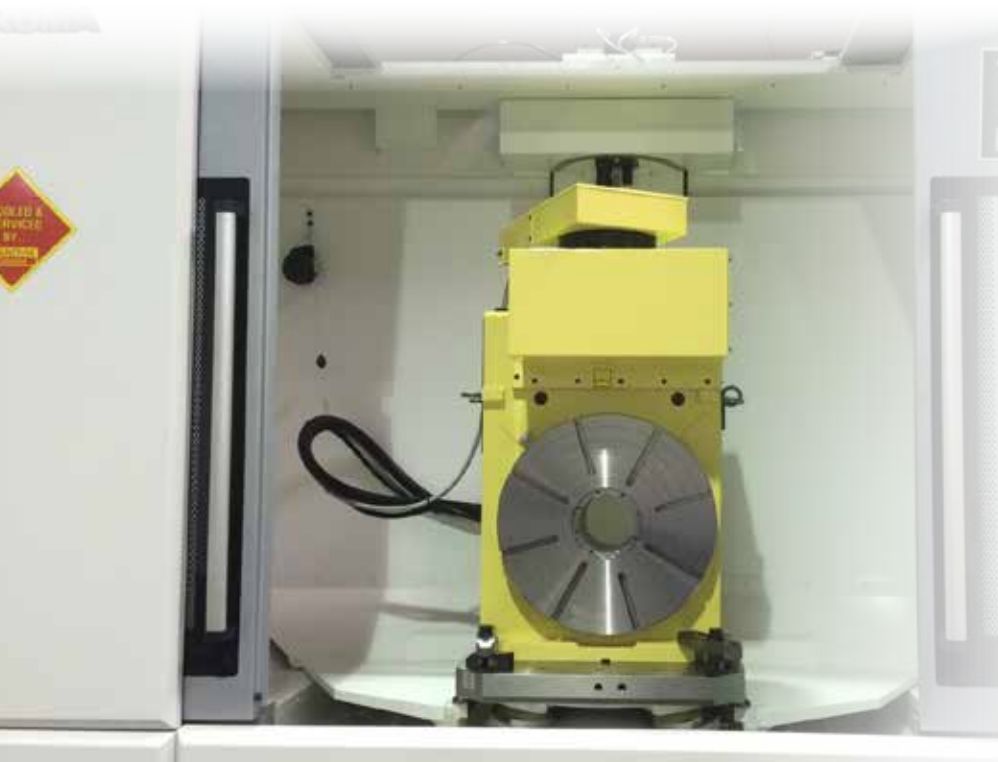

### OTHER BRANDS



















Bolt-on bronze wheel to a two-piece faceplate and quill design. Configuration relies on the malleability of the worm wheel to deform around the shape of the worm screw to eliminate backlash.



← Bolt-on faceplate to quill base.

← Soft worm wheels wear much quicker, resulting in indexing inaccuracies and unnecessary maintenance.

# OKUMA ROTARY TABLE MATRIX

Machine	M460-VE	M560-V	MB-46VA/B	MB56-VA/B	MB-66VA/B	MA-650VB	MA-550VB
 CNC180	—	✓	✓	✓	—	—	—
 CNC202/NCT200	—	✓	✓	✓	—	—	—
 CNC260	—	—	✓	✓	✓	✓	✓
 CNC302	✓	✓	✓	✓	✓	✓	✓
 CNC321	—	—	—	—	✓	✓	✓
 CNC401	—	—	—	—	✓	✓	✓
 CNC601OSP4	—	—	—	—	—	—	—
 CNCB350OSP4	—	—	—	—	✓	✓	✓
 CNCB450OSP4	—	—	—	—	✓	✓	✓
 5AX-130OSP4	✓	✓	✓	✓	—	✓	✓
 5AX-201OSP4	✓	✓	✓	✓	✓	✓	✓
 5AX-230OSP4	—	—	—	—	✓	✓	✓
 5AX-250OSP4	—	—	—	—	✓	✓	✓
 5AX-350OSP4	—	—	—	—	—	—	—
 CNC260TOSP4	—	—	—	—	—	—	—
 CNC321TOSP4	—	—	—	—	—	—	—
 CNC401TOSP4	—	—	—	—	—	—	—
 CNC601TOSP4	—	—	—	—	—	—	—



\*For left hand mount motor style, back mount motor style, multi-spindle units, and interfaces for P200 controllers please contact us.



# OKUMA ROTARY TABLE MATRIX



MILLAC 761V	MILLAC 852V	MILLAC 1052VII	MA-500HA/B	MA-600HA/B	MA-800HB	MB-4000H	MB-5000H	MB-8000H
—	—	—	—	—	—	—	—	—
—	—	—	—	—	—	—	—	—
—	—	—	—	—	—	—	—	—
✓	—	—	—	—	—	—	—	—
✓	✓	—	—	—	—	—	—	—
✓	✓	✓	—	—	—	—	—	—
✓	✓	✓	—	—	—	—	—	—
✓	—	—	—	—	—	—	—	—
✓	✓	—	—	—	—	—	—	—
—	—	—	—	—	—	—	—	—
—	—	—	—	—	—	—	—	—
—	—	—	—	—	—	—	—	—
—	—	—	—	—	—	—	—	—
—	✓	—	—	—	—	—	—	—
—	✓	✓	—	—	—	—	—	—
—	—	—	—	—	—	✓	—	—
—	—	—	✓	—	—	—	✓	—
—	—	—	✓	✓	—	—	✓	—
—	—	—	—	✓	✓	—	—	✓



\*For left hand mount motor style, back mount motor style, multi-spindle units, and interfaces for P200 controllers please contact us.

# ROTARY TABLE SPECIFICATIONS

## CNC180OSP4



Faceplate Diameter:	7.09" (180mm)
Brake System:	AIR
Brake Torque:	223.5 ft. lbs. (303 Nm)
Min. Increment:	0.001°
Rotation Speed (RPM):	22.2
Total Reduction Ratio:	1/90
Indexing Accuracy (sec.):	±20
Net Weight:	99 lbs. (44.9 kg.)
Driving Torque:	53 ft. lbs. (71.9 Nm)
Repeatability (Arc sec.):	±4

- Compact design allows better utilization of machine work envelope
- High clamping force for aggressive machining
- Hardened gears eliminates constant backlash adjustment
- High speed (44.4 RPM) available upon request
- Large ID hole with H7 tolerance allows for accurate fixture repeatability

## CNC202OSP4



Faceplate Diameter:	7.87" (200mm)
Brake System:	AIR
Brake Torque:	223.5 ft. lbs. (303 Nm)
Min. Increment:	0.001°
Rotation Speed (RPM):	22.2
Total Reduction Ratio:	1/90
Indexing Accuracy (sec.):	±20
Net Weight:	121 lbs. (54.9 kg.)
Driving Torque:	106 ft. lbs. (143.7 Nm)
Repeatability (Arc sec.):	±4

- Compact design allows better utilization of machine work envelope
- High clamping force for aggressive machining
- Hardened gears eliminates constant backlash adjustment
- High speed (44.4 RPM) available upon request
- Large ID hole with H7 tolerance allows for accurate fixture repeatability

## CNC260POSP4



Faceplate Diameter:	10.24" (260mm)
Brake System:	AIR
Brake Torque:	1,054 ft. lbs. (1,429 Nm)
Min. Increment:	0.001°
Rotation Speed (RPM):	16.6
Total Reduction Ratio:	1/120
Indexing Accuracy (sec.):	20
Net Weight:	253 lbs. (114.8 kg.)
Driving Torque:	141.6 ft. lbs. (192 Nm)
Repeatability (Arc sec.):	±4

- Highest weight load capacity in its class
- New generation air brake system allows for superior clamping force
- Large offering of support tailstocks and support tables for all fixturing requirements
- Highest accuracy and repeatability for true positioning





# ROTARY TABLE SPECIFICATIONS

## CNC302PSP4



Faceplate Diameter:	11.8" (300mm)
Brake System:	AIR
Brake Torque:	1,054 ft. lbs. (1,429 Nm)
Min. Increment:	0.001°
Rotation Speed (RPM):	16.6
Total Reduction Ratio:	1/120
Indexing Accuracy (sec.):	20
Net Weight:	264 lbs. (119.7 kg.)
Driving Torque:	141.6 ft. lbs. (192 Nm)
Repeatability (Arc sec.):	±4

- Highest weight load capacity in its class
- New generation air brake system allows for superior clamping force
- Large offering of support tailstocks and support tables for all fixturing requirements
- Highest accuracy and repeatability for true positioning

## CNC321OSP4



Faceplate Diameter:	12.6" (321mm)
Brake System:	AIR / HYDRAULIC
Brake Torque:	1,298 ft. lbs. (1,759.9 Nm)
Min. Increment:	0.001°
Rotation Speed (RPM):	22.2
Total Reduction Ratio:	1/90
Indexing Accuracy (sec.):	15
Net Weight:	441 lbs. (200 kg.)
Driving Torque:	318 ft. lbs. (431.2 Nm)
Repeatability (Arc sec.):	±4

- The rotary table can be used vertically or horizontally depending on the application
- 4" through-hole
- Suitable for indexing and rotational milling on a wide variety of work pieces
- Strong hydraulic brake allows for high braking torque

## CNC401OSP4



Faceplate Diameter:	15.8" (401mm)
Brake System:	AIR / HYDRAULIC
Brake Torque:	1,298 ft. lbs. (1,759.9 Nm)
Min. Increment:	0.001°
Rotation Speed (RPM):	22.2
Total Reduction Ratio:	1/90
Indexing Accuracy (sec.):	15
Net Weight:	496 lbs. (225 kg.)
Driving Torque:	318 ft. lbs. (431.2 Nm)
Repeatability (Arc sec.):	±4

- 4" through-hole
- Tubular bearings mounted directly under the edge of the faceplate absorb shock and dampen vibration

## CNC302POSP4

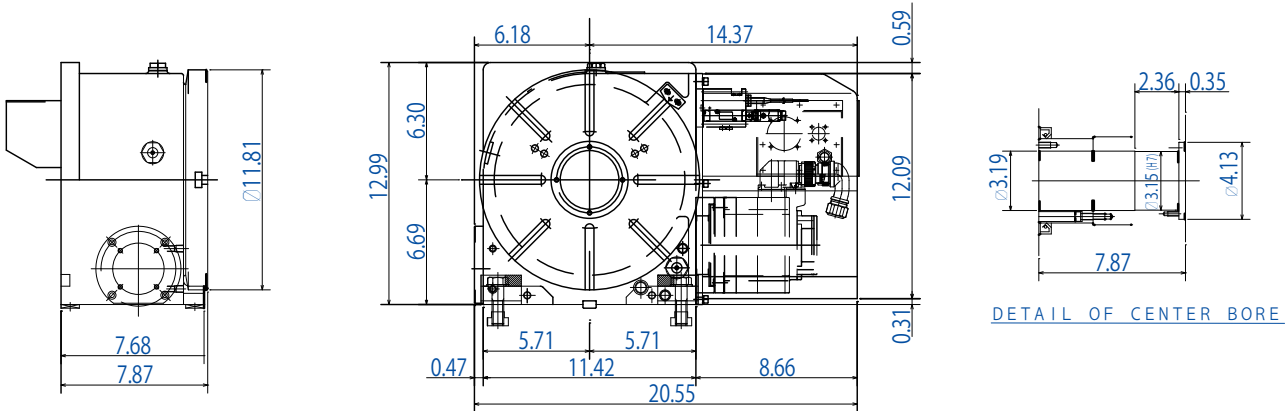

## CNC321OSP4

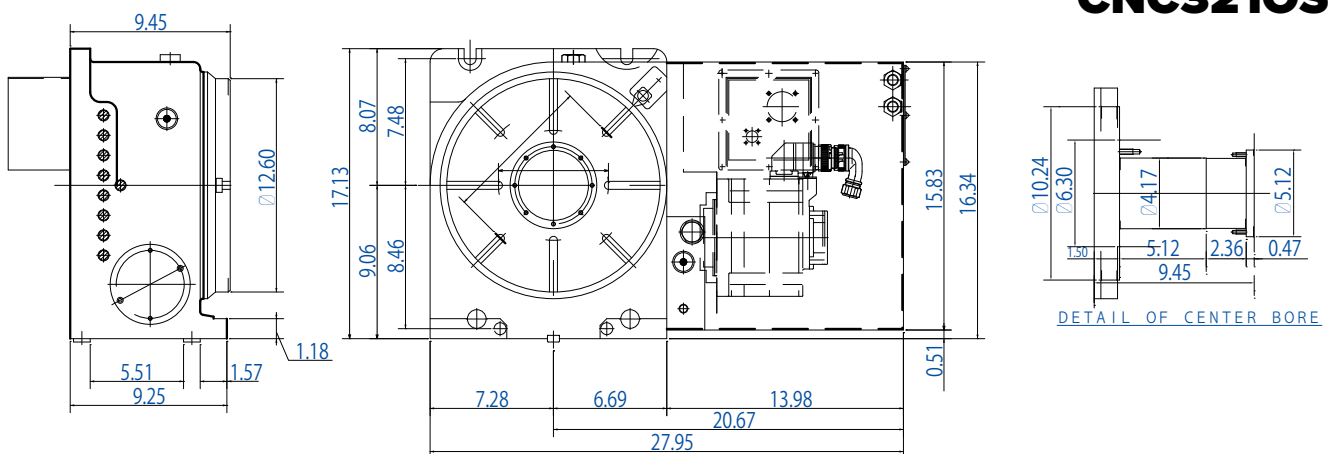

## CNC401OSP4

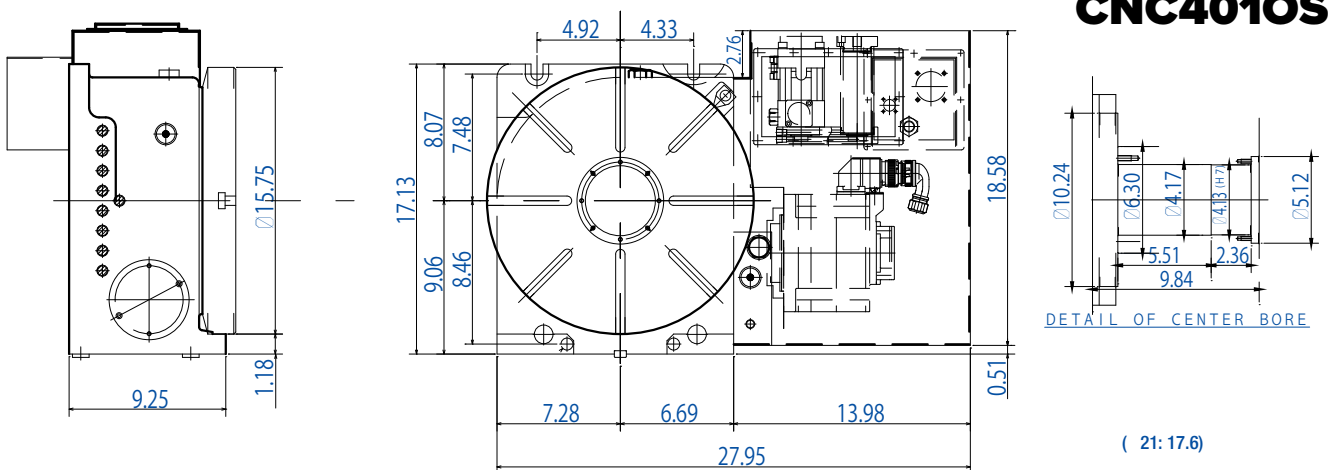

Please contact Lyndex-Nikken to confirm Okuma / Nikken Rotary Table working envelope. Drawings are subject to change.

# ROTARY TABLE SPECIFICATIONS

## NCT200



Faceplate Diameter:	7.87" (200 mm)
Brake System:	AIR
Brake Torque:	663 ft. lbs. (898.9 Nm)
Min. Increment:	0.001°
Rotation Speed (RPM):	33.3
Total Reduction Ratio:	1/90
Indexing Accuracy (sec.):	±20
Net Weight:	143 lbs. (64.9 kg.)
Driving Torque:	111 ft. lbs. (150.5 Nm)
Repeatability (Arc sec.):	±4

- High clamping torque in a compact footprint
- Advanced clamping system enables reliable indexing accuracy, repeatability, and exceptional braking force
- High rigidity of new drive system ensures long-term accuracy and precision
- High speed Z Type rotary table is also available to reduce cycle time and enhance productivity
- Customization is available for face plates, rotary joints, angular plates, and support tables

## NCT200E (without faceplate)



Photo: NCT200EFA

Diameter:	5.12" (130 mm)
Brake System:	AIR
Brake Torque:	663 ft. lbs. (898.9 Nm)
Min. Increment:	0.001°
Rotation Speed (RPM):	33.3
Total Reduction Ratio:	1/90
Indexing Accuracy (sec.):	±20
Net Weight:	137 lbs. (62 kg.)
Driving Torque:	111 ft. lbs. (150.5 Nm)
Repeatability (Arc sec.):	±4

- High clamping torque in a compact footprint
- Advanced clamping system enables reliable indexing accuracy, repeatability, and exceptional braking force
- High rigidity of new drive system ensures long-term accuracy and precision
- High speed Z Type rotary table is also available to reduce cycle time and enhance productivity
- Customization is available for face plates, rotary joints, angular plates, and support tables





# ROTARY TABLE SPECIFICATIONS

## 5AX-130OSP4

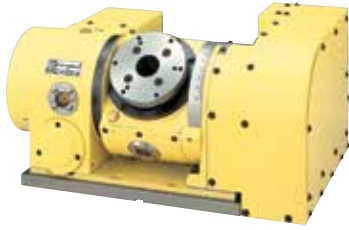

Faceplate Diameter:	4.13" (105mm)
Brake System:	AIR
Brake Torque:	Rotary: 151 ft. lbs. (204.7 Nm) Tilting: 223.5 ft. lbs. (303 Nm)
Min. Increment:	0.001°
Rotation Speed (RPM):	Rotary: 22.2 Tilting: 11.1
Total Reduction Ratio:	Rotary: 1/90 Tilting: 1/180
Indexing Accuracy (sec.):	Rotary: ±30 Tilting: 60
Net Weight:	219.3 lbs. (99.5 kg.)
Driving Torque:	53 ft. lbs. (71.9 Nm)
Repeatability (Arc sec.):	Rotary: ±4 Tilting: ±6

- Significant cost reduction by eliminating multiple set ups
- Compact design leaves majority of machine table open for multiple vises
- High accuracy for true positioning parts (repeatable within 4 arc seconds)
- Full contouring machining capability
- Highest clamping force within its class

## 5AX-201OSP4



*Hydraulic brake for additional clamping force is available upon request. Please contact us for more information.*

Faceplate Diameter:	7.87" (200mm)
Brake System:	AIR
Brake Torque:	Rotary: 223.5 ft. lbs. (303 Nm) Tilting: 223.5 ft. lbs. (303 Nm)
Min. Increment:	0.001°
Rotation Speed (RPM):	Rotary: 22.2 Tilting: 16.6
Total Reduction Ratio:	Rotary: 1/90 Tilting: 1/120
Indexing Accuracy (sec.):	Rotary: ±15 Tilting: 60
Net Weight:	352.7 lbs. (160 kg.)
Driving Torque:	53 ft. lbs. (71.9 Nm)
Repeatability (Arc sec.):	Rotary: ±4 Tilting: ±6

- Compact design with powerful clamping
- Low profile of the trunnion provides greater work space for large or long parts
- Large ID hole with H7 tolerance allows for accurate fixture repeatability
- Full contouring machining capability

## 5AX-1300SP4

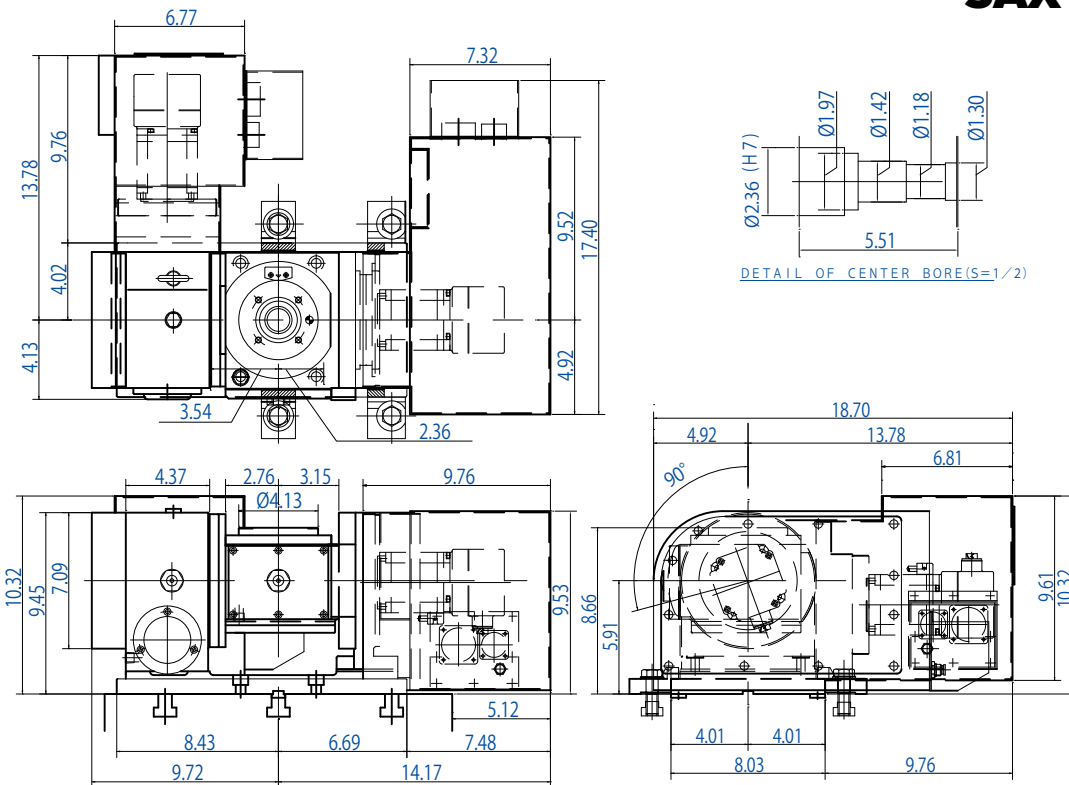

## 5AX-2010SP4

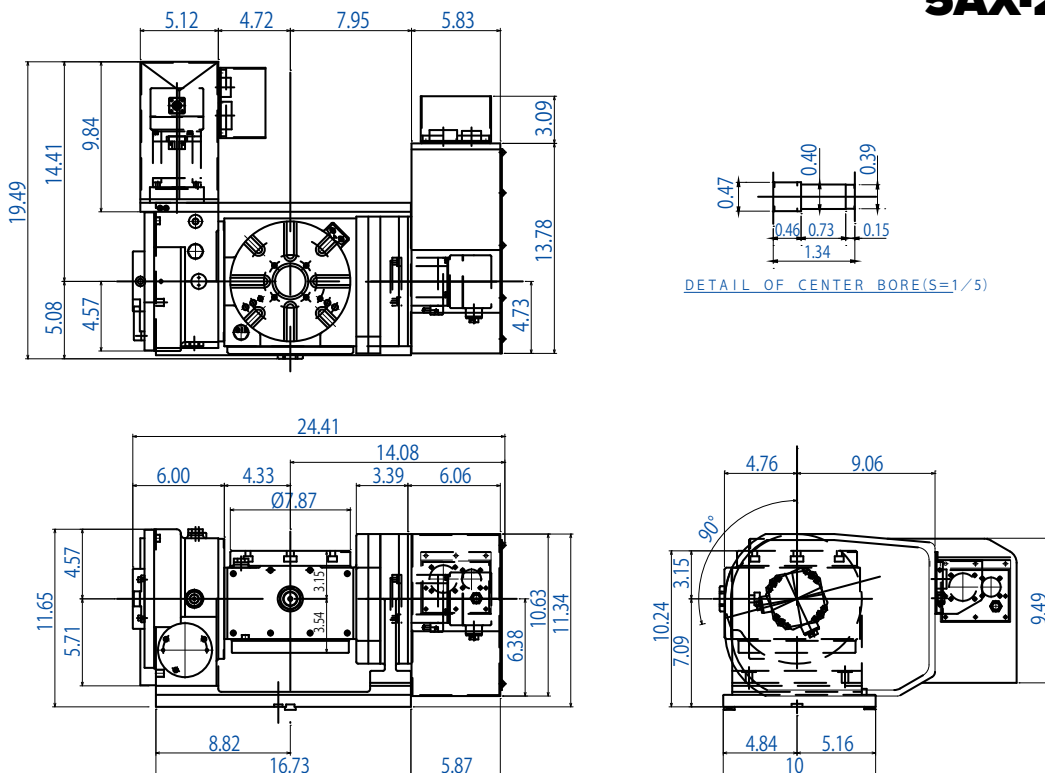

Please contact Lyndex-Nikken to confirm Okuma / Nikken Rotary Table working envelope. Drawings are subject to change.



# ROTARY TABLE SPECIFICATIONS

## 5AX-250OSP4



Faceplate Diameter:	9.8" (250mm)
Brake System:	HYDRAULIC
Brake Torque:	Rotary: 433.6 ft. lbs. (587.9 Nm) Tilting: 361.3 ft. lbs. (489.9 Nm)
Min. Increment:	0.001°
Rotation Speed (RPM):	Rotary: 22.2 Tilting: 11.1
Total Reduction Ratio:	Rotary: 1/90 Tilting: 1/120
Indexing Accuracy (sec.):	Rotary: 20 Tilting: 60
Net Weight:	639.3 lbs. (290 kg)
Driving Torque:	106.2 ft. lbs. (144 Nm)
Repeatability (Arc sec.):	Rotary: ±4 Tilting: ±6

- Significant cost reduction by eliminating multiple set ups
- Improve parts quality and maximize productivity
- Full contouring machining capability
- Highest clamping force within its class

## 5AX-350OSP4



Faceplate Diameter:	13.78" (350mm)
Brake System:	HYDRAULIC
Brake Torque:	Rotary: 1,156.3 ft. lbs. (1,567.7 Nm) Tilting: 1,156.3 ft. lbs. (1,567.7 Nm)
Min. Increment:	0.001°
Rotation Speed (RPM):	Rotary: 22.2 Tilting: 22.2
Total Reduction Ratio:	Rotary: 1/90 Tilting: 1/90
Indexing Accuracy (sec.):	Rotary: 20 Tilting: 60
Net Weight:	926 lbs. (420 kg.)
Driving Torque:	212.4 ft. lbs. (288 kg.)
Repeatability (Arc sec.):	Rotary: ±4 Tilting: ±6

- Significant cost reduction by eliminating multiple set ups
- Improve parts quality and maximize productivity
- Full contouring machining capability
- Highest clamping force within its class

## 5AX-2500SP4

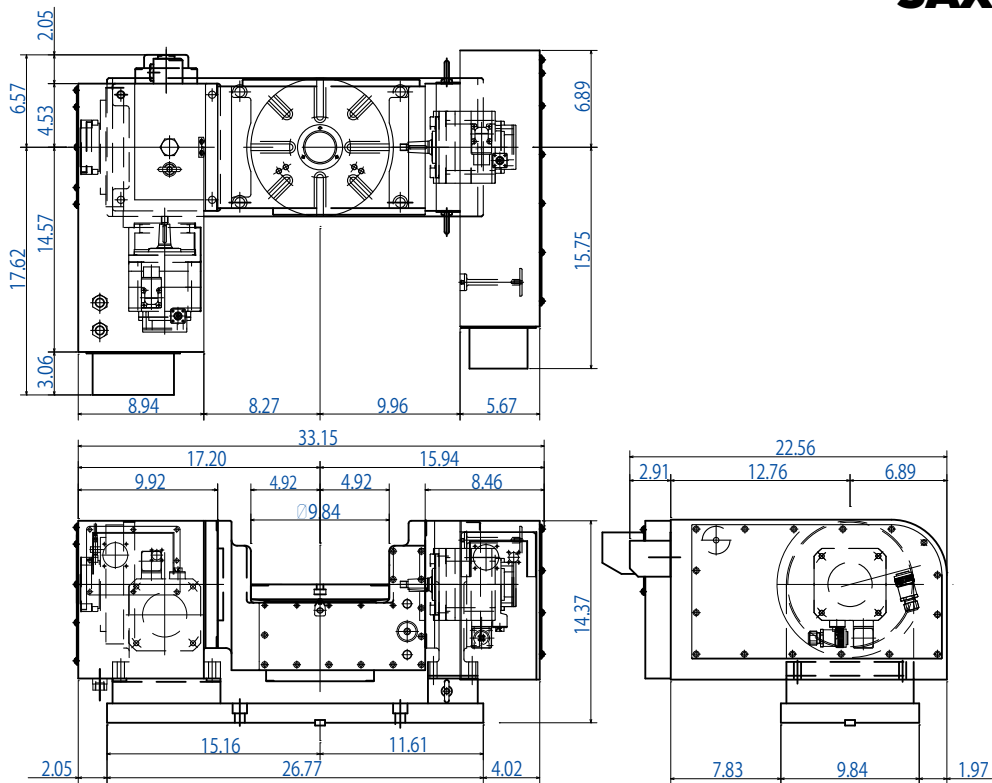

## 5AX-3500SP4

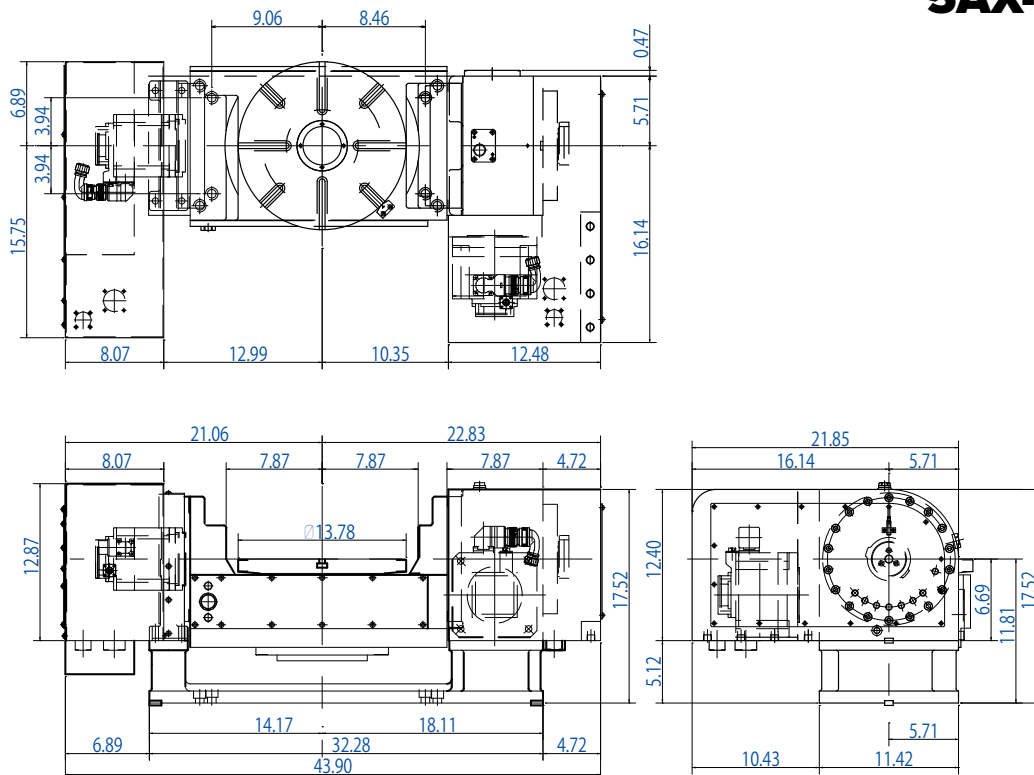

Please contact Lyndex-Nikken to confirm Okuma / Nikken Rotary Table working envelope. Drawings are subject to change.

# ROTARY TABLE SPECIFICATIONS

## CNC260TOSP4



Faceplate Diameter:	10/12" (260/304mm)
Brake System:	AIR
Brake Torque:	433.6 ft. lbs. (587.9 Nm)
Min. Increment:	0.001°
Rotation Speed (RPM):	16.6
Total Reduction Ratio:	1/120
Indexing Accuracy (sec.):	20
Net Weight:	353 lbs. (160.1 kg.)
Driving Torque:	141.6 ft. lbs. (192 Nm)
Repeatability (Arc sec.):	±4

- Swing box application available for installation onto Horizontal M/C
- To avoid interference, the drive motor is mounted on the top side of the table for horizontal machines and special purpose applications

## CNC321TOSP4



Faceplate Diameter:	12.6" (321mm)
Brake System:	HYDRAULIC
Brake Torque:	1,298 ft. lbs. (1,759.9 Nm)
Min. Increment:	0.001°
Rotation Speed (RPM):	22.2
Total Reduction Ratio:	1/120
Indexing Accuracy (sec.):	15
Net Weight:	485 lbs. (220 kg.)
Driving Torque:	424.8 ft. lbs. (576 Nm)
Repeatability (Arc sec.):	±4

- Swing box application available for installation onto Horizontal M/C
- To avoid interference, the drive motor is mounted on the top side of the table for horizontal machines and special purpose applications



## CNC260TOSP4

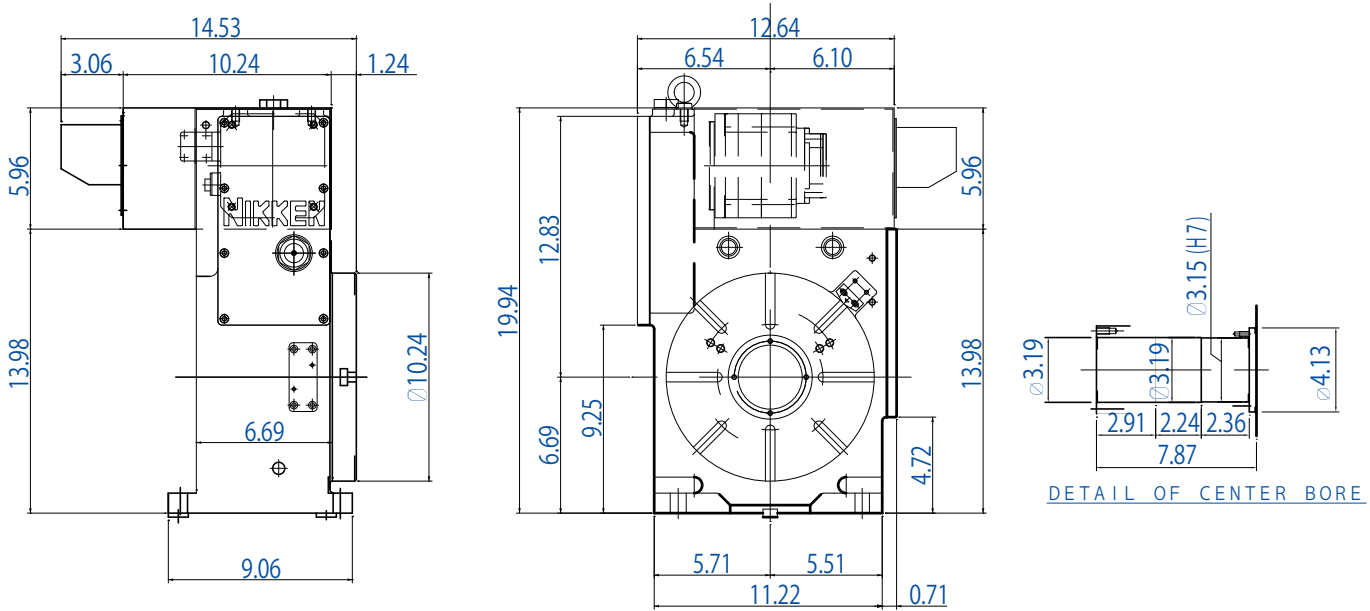

## CNC321TOSP4

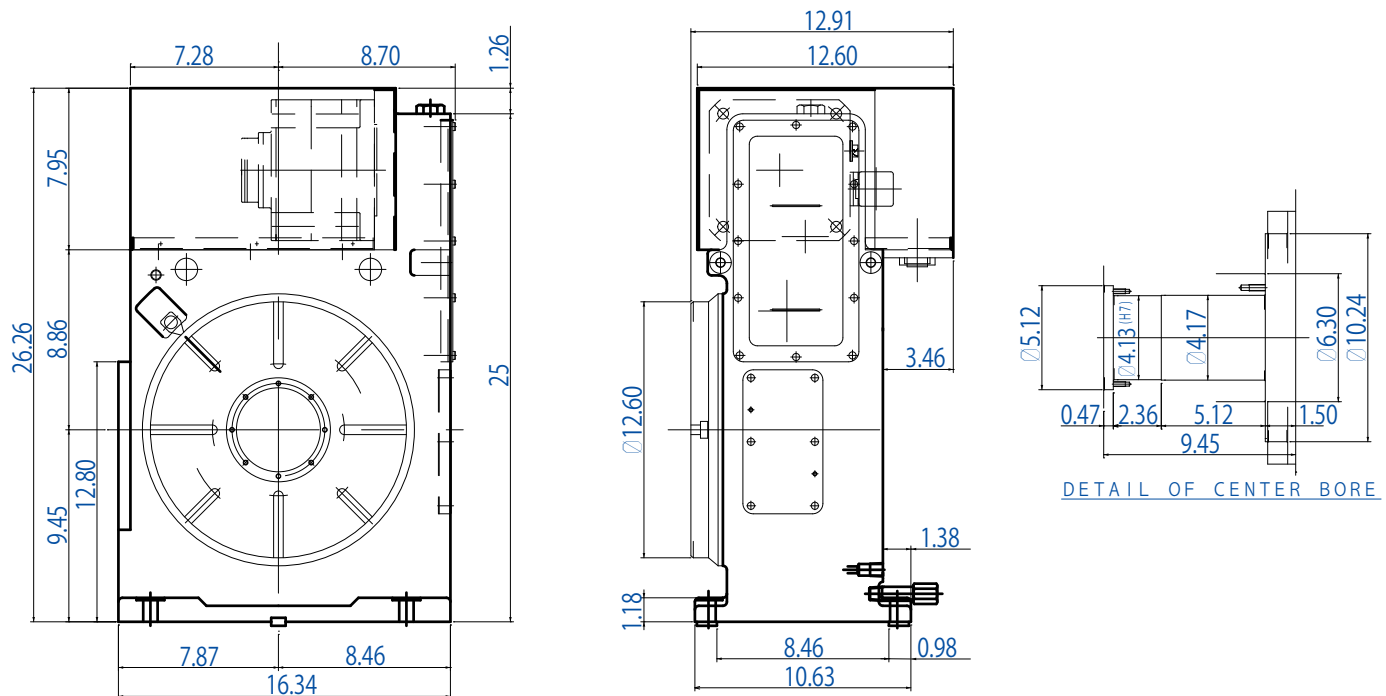

Please contact Lyndex-Nikken to confirm Okuma / Nikken Rotary Table working envelope. Drawings are subject to change.

# ROTARY TABLE SPECIFICATIONS

## CNC401TOSP4



Faceplate Diameter:	15.8" (401mm)
Brake System:	AIR / HYDRAULIC
Brake Torque:	1,298 ft. lbs. (1,759.9 Nm)
Min. Increment:	0.001°
Rotation Speed (RPM):	22.2
Total Reduction Ratio:	1/120
Indexing Accuracy (sec.):	15
Net Weight:	540 lbs. (244.9 kg.)
Driving Torque:	424.8 ft. lbs. (576 Nm)
Repeatability (Arc sec.):	±4

- Swing box application available for installation onto Horizontal M/C
- To avoid interference, the drive motor is mounted on the top side of the table for horizontal machines and special purpose applications

## CNC601TOSP4



Faceplate Diameter:	23.6" (601mm)
Brake System:	HYDRAULIC
Brake Torque:	3,433 ft. lbs. (4,654.5 Nm)
Min. Increment:	0.001°
Rotation Speed (RPM):	11.1
Total Reduction Ratio:	1/180
Indexing Accuracy (sec.):	15
Net Weight:	1,157 lbs. (524.8 kg.)
Driving Torque:	673.2 ft. lbs. (912.7 Nm)
Repeatability (Arc sec.):	±4

- Swing box application available for installation onto Horizontal M/C
- To avoid interference, the drive motor is mounted on the top side of the table for horizontal machines and special purpose applications

## CNC401TOSP4

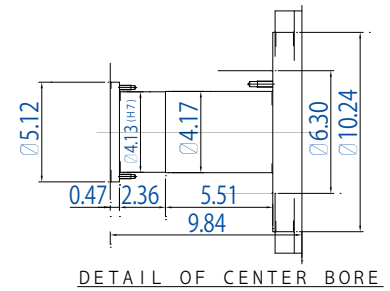
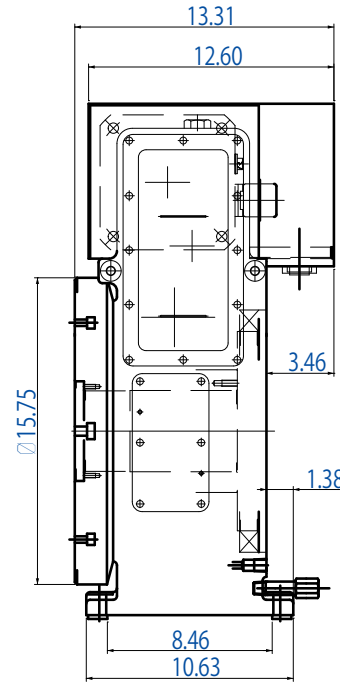
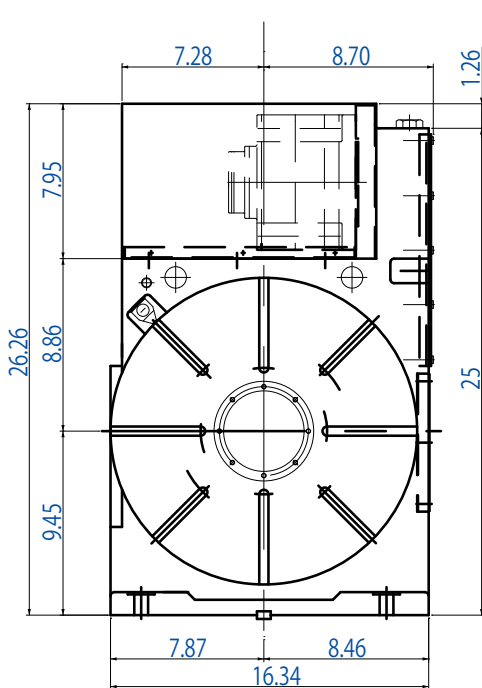

## CNC601TOSP4

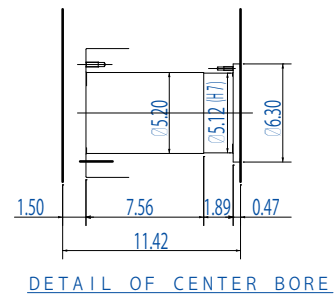
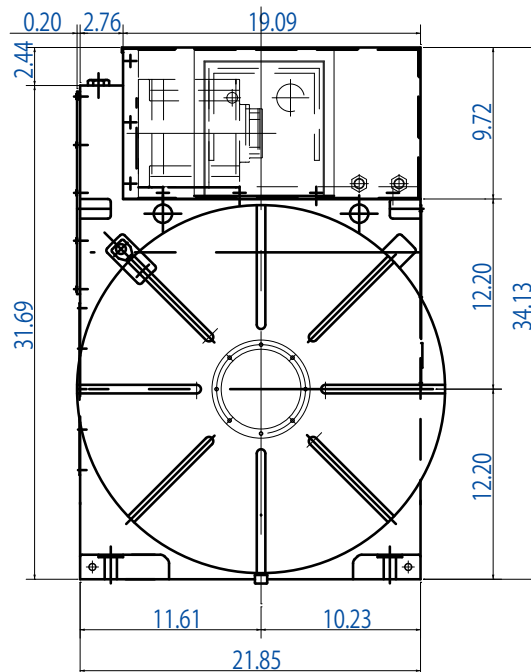
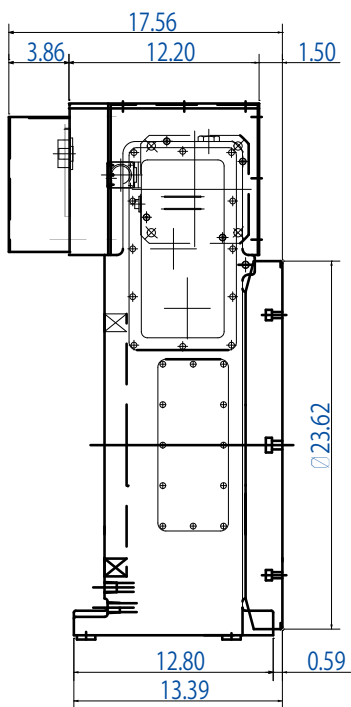

Please contact Lyndex-Nikken to confirm Okuma / Nikken Rotary Table working envelope. Drawings are subject to change.

# M460-VE ROTARY TABLE LAYOUT (4TH/5TH AXIS)

## 4TH AXIS

M460-VE	CNC180/202	CNC260/302
A	26.54"	24.65"
B	5.32"	6.69"
C	18.70"	17.32"

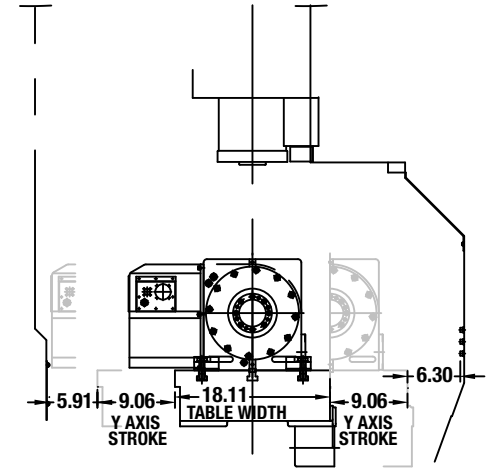
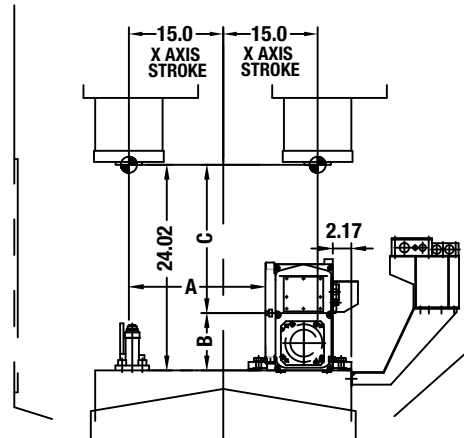

## 5TH AXIS

M460-VE	5AX-130	5AX-201
A	25.98"	24.84"
B	22.99"	21.69"
C	15.36"	13.78"
D	18.11"	16.93"

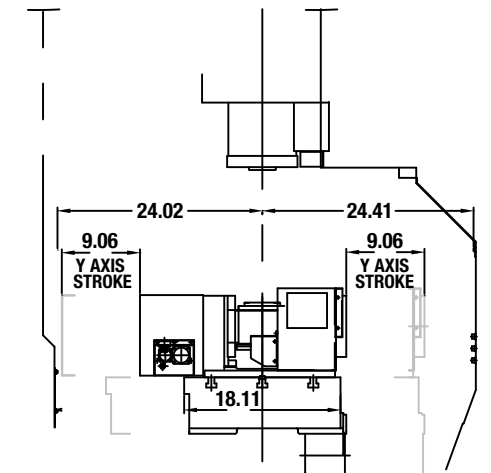
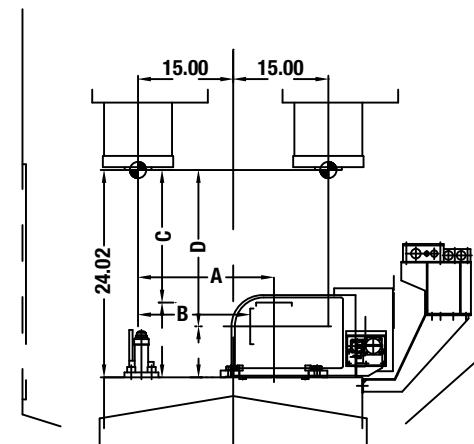

## LYNDEX-NIKKEN TECHNICAL ENGINEERING SUPPORT

- 2-D and 3-D modeling support for clearance verification
- 3-D model support for programming integration
- Image rendering for proposals

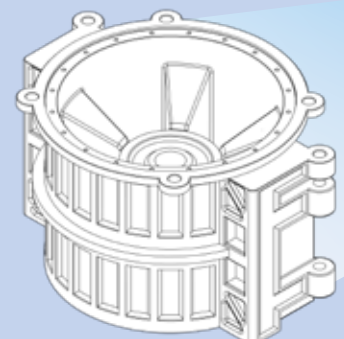



# M560-V ROTARY TABLE LAYOUT (4TH/5TH AXIS)

## 4TH AXIS

M560-V	CNC180/202	CNC260/302
A	38.11"	36.22"
B	5.32"	6.69"
C	18.70"	17.32"

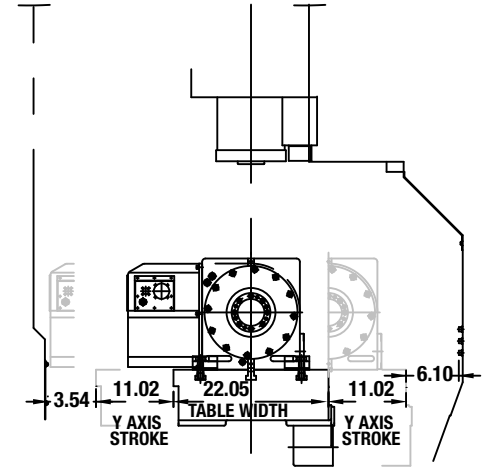
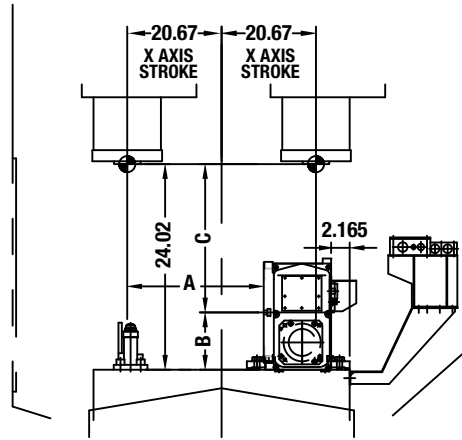

## 5TH AXIS

M560-V	5AX-130	5AX-201
A	37.32"	36.18"
B	34.57"	33.03"
C	15.36"	13.78"
D	18.11"	16.93"

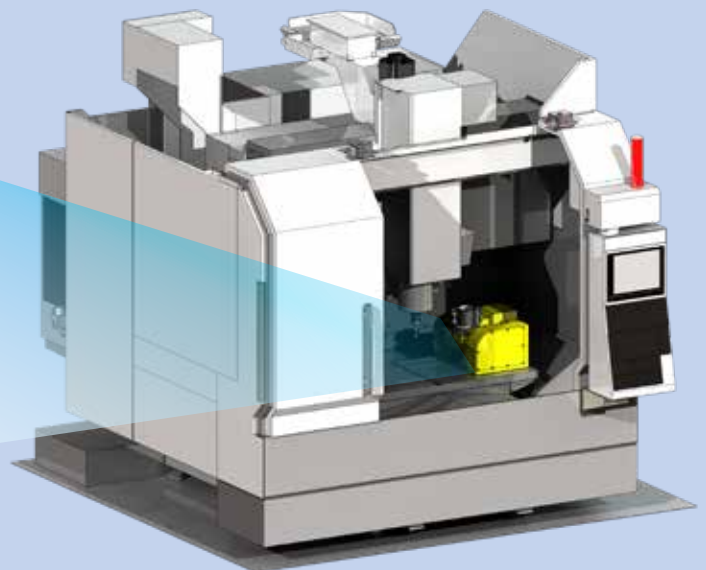
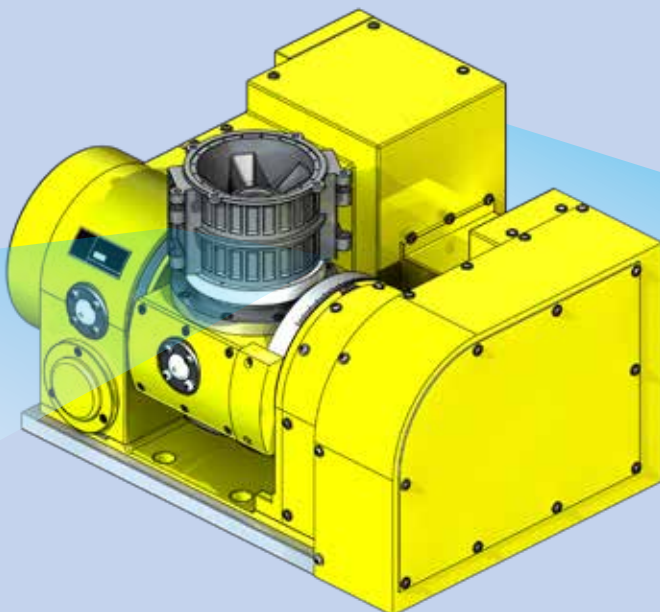
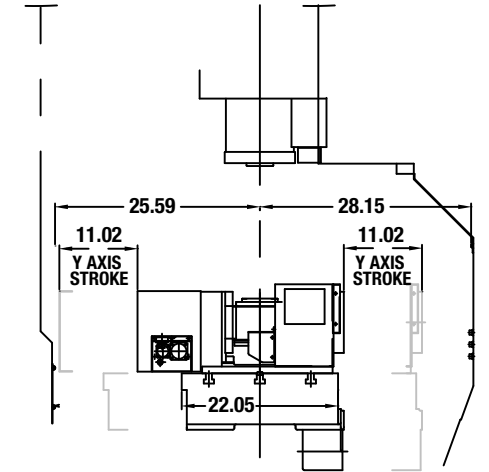
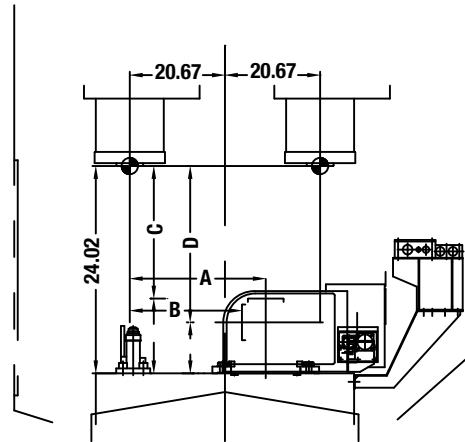

# ROTARY TABLE ACCESSORIES



MODEL	Manual Tailstock Stroke: 0.60" (15mm)	Air/Hyd. Tailstock Stroke: 2.36" (60mm)	Support Table Built-in brake(Hyd.)	Scroll Chuck
CNC105	P-105S	PBA-105	TAT105	R-4
CNC180, CNC202, NCT200	P-125S	PBA-135	TAT170	180 = R-6 / 202 = R-7
CNC260, CNC302	P-170S	PBA-170	TAT250	R-9 / R-10 / R-12A
CNC321, CNC401	P-230S	PBA-230	TAT320	R-12B
CNC501, CNC601	P-310S	-	TAT500, TAT600	-
CNC100-2W/3W/4W	-	PBA-105-2,3,4W	-	-
CNC260B, CNC302B	P-170S	PBA-170	TAT250	R-9 / R-10 / R-12A
CNC321B, CNC401B	P-230S	PBA-230	TAT320, TAT400	R-12B
5AX-130	P-150S	PBA-150	-	R-4
5AX-201, 5AX-200II	P-170S	PBA-180	-	R-7 / R-8
NST250	P-150S	-	-	-

## MANUAL TAILSTOCK

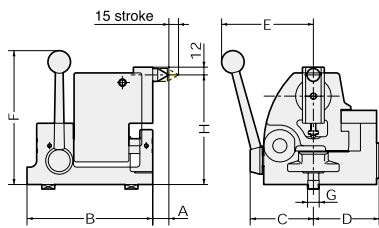

PART#	H Center Height	A	B	C	D	E	F	G	Weight (lbs.)
P-105S	4.01-4.33	1.06	5.91	2.99	2.91	4.72	7.68	0.55	22
P-125S	4.02-5.31	1.06	5.91	2.99	2.91	4.72	8.27	0.55	25.5
P-150S	5.70-6.29	0.98	7.68	3.86	4.02	5.71	8.27	0.71	48.5
P-170S	6.29-7.08	0.98	7.68	3.86	4.02	5.71	8.27	0.71	49.6
P-230S	8.66-9.44	0.98	7.68	3.86	4.02	5.71	9.84	0.71	59.5

## AIR/HYD. TAILSTOCK

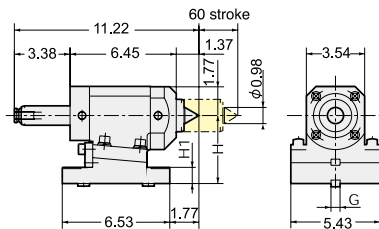

PART#	H Center Height	H <sub>1</sub>	G	Thrust (N)		Weight (lbs.)
				Air 0.5 MPa	Hyd. 2 MPa	
PBA-105	4.13	0.98	0.55	1176	4733	33
PBA-135	5.31	2.17	0.55	1176	4733	44
PBA-150	5.91	2.76	0.71	1176	4733	48.5
PBA-170	6.69	3.54	0.71	1176	4733	54
PBA-180	7.09	3.94	0.71	1176	4733	56

## SUPPORT TABLE

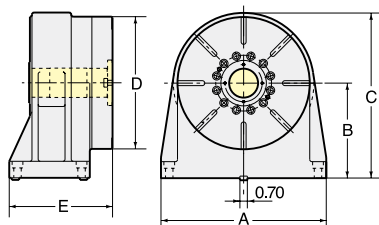

PART#	A	B	C	D	E	Brake System	Brake Torque (ft.lbs)	Weight (lbs.)
TAT105	6.10	4.13	6.89	4.13	4.45	AIR	202.8	35
TAT170	6.10	5.31	8.66	6.69	5.43	AIR	202.8	55
TAT250	9.84	6.69	11.61	9.84	5.71	AIR/HYD.	82.6/578.2	110
TAT320	15.75	9.06	15.35	12.60	9.84	AIR	1084	264.5
TAT400	15.75	9.06	16.93	15.75	9.84	AIR	1084	308.6
TAT500	18.90	12.20	22.05	19.69	9.84	AIR	1084	441

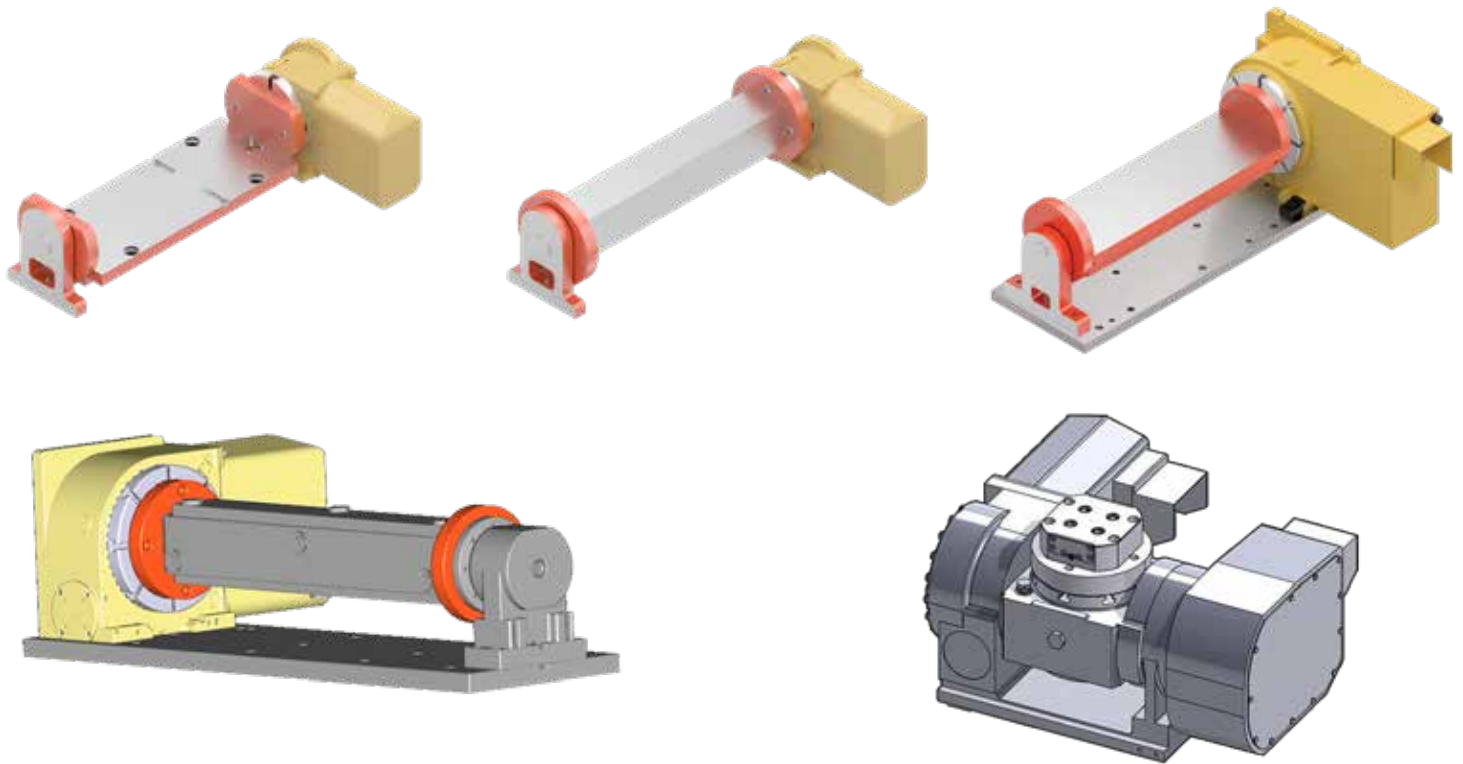

## WORKHOLDING PARTNERS:



**Lyndex-Nikken is dedicated to providing not only the highest quality of equipment, but also the highest quality of service and customer care.**

## HOW CAN WE HELP?

Our fully equipped Service Department has over 30 years experience enabling us to offer complete and timely support for all Lyndex-Nikken products, including: CNC Rotary Tables, Live Tools & Angle Heads, Toolholders, Presetters.

We fully stock all internal components to provide expedited and cost-effective maintenance program and rebuilds.

Our comprehensive technical and repair services is here to protect your investment. Please contact us to discuss any requirements in more detail: (847) 367-4800.

## IN-HOUSE SERVICES

- Fault diagnosis and repair work
- Motor fitment and CNC M/C preparation
- Cable manufacture and guard modifications
- Brake booster upgrades
- Rotary table retrofit service for installation on different machining centers
- Rotary table check-up program & preventative maintenance
- Rotary table installation
- Tool repair and calibrations
- Complete rotary table refurbishment
- Customer training and support

## FREQUENTLY ASKED QUESTIONS

### What is the process for sending a rotary table in for repair?

If you are an end-user, please contact your local Lyndex-Nikken distributor to obtain a RGA (Return Goods Authorization). You will need to refer the part number of your unit and what problem you are currently facing with it. Once the distributor provides you with the RGA, you can send your rotary table to our repair facility in Illinois for evaluation. We will inspect it, then quote the distributor the repair charges. If you agree to have it repaired, contact the distributor. The distributor will issue a Purchase Order to Lyndex-Nikken for the work. Inspection fee may apply. Please ship all tables in secured crate, via truck service to ensure it is properly protected.

### What is the normal turnaround time for repairs?

Usually within 5-10 business days from date of receipt. Expedited service can be arranged.

### What motor gear oil is recommended?

Mobil Gear 600 XP 100

### What hydraulic oil is recommended?

Mobil 1 DTE 20 Hydraulic Fluid

## ROTARY TABLE CHECK-UP PROGRAM

Rotary tables play a pivotal role in helping to ensure the effective and precise machining of parts. So, being proactive by performing regular maintenance on rotary tables is essential to help ensure their continued reliability, accuracy, and longevity. Neglecting maintenance can lead to decreased performance, increased downtime, and potentially costly repairs.

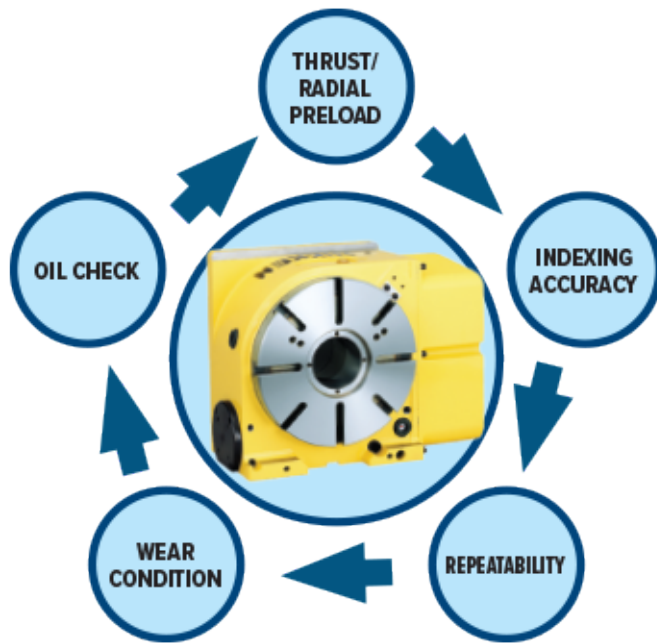

## PROACTIVE ON-SITE ROTARY TABLE INSPECTION

Lyndex-Nikken offers a Check-Up Program that provides proactive on-site inspection of your Nikken rotary tables to help provide early detection of failure points in the manufacturing process.

A Lyndex-Nikken technician will come to your facility and evaluate your Nikken rotary tables backlash, braking system, and overall condition. We will provide you the test data of your Nikken rotary tables, review the data with you, and give recommendations to help eliminate downtime.

## BY BEING PROACTIVE, HERE IS HOW YOU CAN BENEFIT:

- **Decreased Downtime:** Our scheduled maintenance checks and diagnostics help identify potential issues before they become major problems, reducing the risk of unexpected downtime.
- **Consistent Part Quality:** A properly maintained rotary table contributes to consistent part quality and maintaining the desired tolerances in the finished parts - essential for meeting customer specifications and maintaining a reliable reputation.
- **Increased Productivity:** Regular maintenance prevents costly production interruptions, enabling you to meet deadlines and fulfill customer orders without delays.
- **Extended Equipment Lifespan:** Proper care and maintenance can significantly extend the life of your CNC automation equipment, providing a higher return on investment over the long term.
- **Cost Savings:** By addressing minor wear and tear early on, you can avoid last minute expensive repairs and replacements down the line.



## SEE OUR ROTARY TABLES IN ACTION

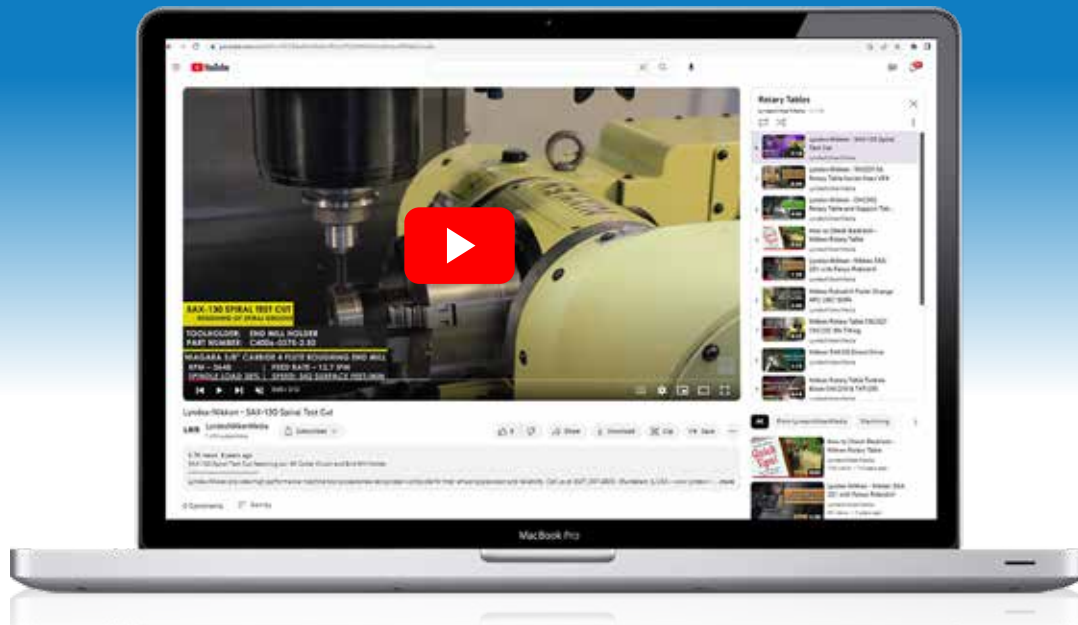

Scan the QR Code to see our full playlist of YouTube videos and discover what our Rotary Tables can do for your business!



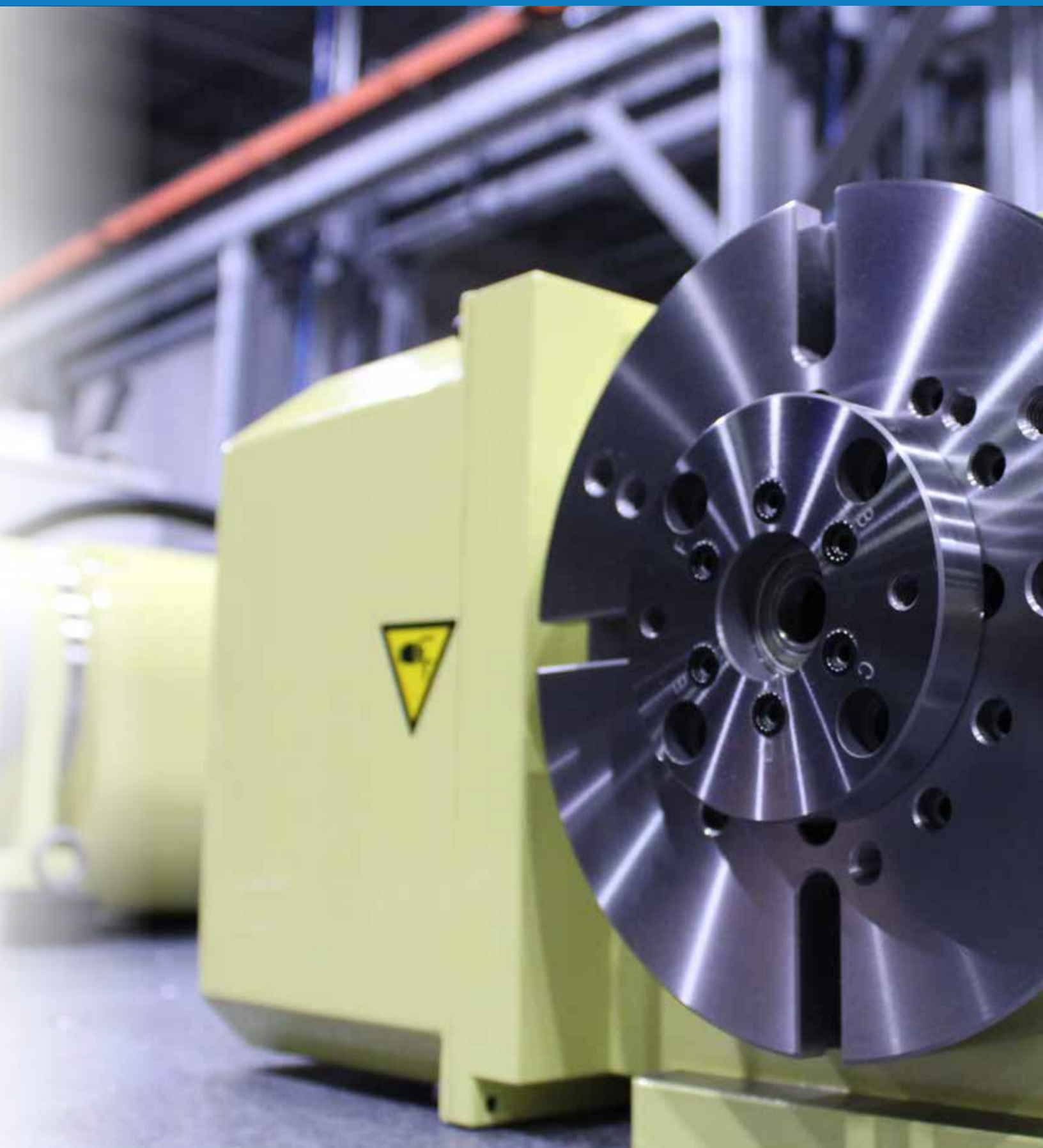

A photograph of the Lyndex-Nikken building exterior, featuring the company name and logo on the facade. The image is overlaid with a blue tint. The logo consists of the words "LYNDEX" and "NIKKEN" stacked vertically, followed by a square icon containing a stylized yellow and blue graphic of a tool or part.

LYNDEX  
NIKKEN

## ABOUT US

At Lyndex-Nikken, we have made it our mission to provide the two most important points to keep you ahead of the competition: advanced technology and the innovation to keep it moving forward. In addition to manufacturing the best machine tool accessories available on the market, our team of highly experienced technicians and product specialists offers unmatched customer service and engineering support to our customers worldwide.



1468 Armour Boulevard | Mundelein, IL 60060  
Phone: 847.367.4800 | Fax: 847.367.4815 | [sales@lyndexnikken.com](mailto:sales@lyndexnikken.com)  
[www.lyndexnikken.com](http://www.lyndexnikken.com)

